



COMPONENT MAINTENANCE MANUAL
B7280

DESCRIPTION AND OPERATION

1. DESCRIPTION

The Temperature Sensor, Model B7280, consists of a calibrated platinum element, RTD, which is located within the tip of a stainless steel probe assembly. The probe assembly is externally threaded for boss mounting on an aircraft duct.

2. OPERATION

The resistance of the RTD varies in direct proportion to changes in the duct air temperature. The RTD is terminated at pins A & B/C of a 3-pin hermetically sealed, stainless steel connector, which is welded to the probe body. This connector provides the interface between the RTD and an associated temperature controller. The controller processes the RTD signal to monitor and regulate the aircraft temperature control system.

3. SPECIFICATIONS

Temperature vs. Resistance Points:

<u>Temperature (°C)</u>	<u>(°F)</u>	<u>Ohms</u>
+0	(+32)	100.00
+100	(+212)	138.50

Connector: 718-8005-08 (or equivalent)

*Mating Connector: FDBA5683ASNK (or equivalent)

Weight: 0.060 Kg (2.116 oz.)

Size:

Probe Tip Diameter: 7.9 mm (.312 in.) (NOM)

Overall Length: 77 mm (3.03 in.) maximum

Mounting Thread: M14 x 1.0-6g

Mounting Hexagon: 26 mm (1.024 in.) across flats

- * This connector is listed for test purposes only, and is not necessarily used on the aircraft.

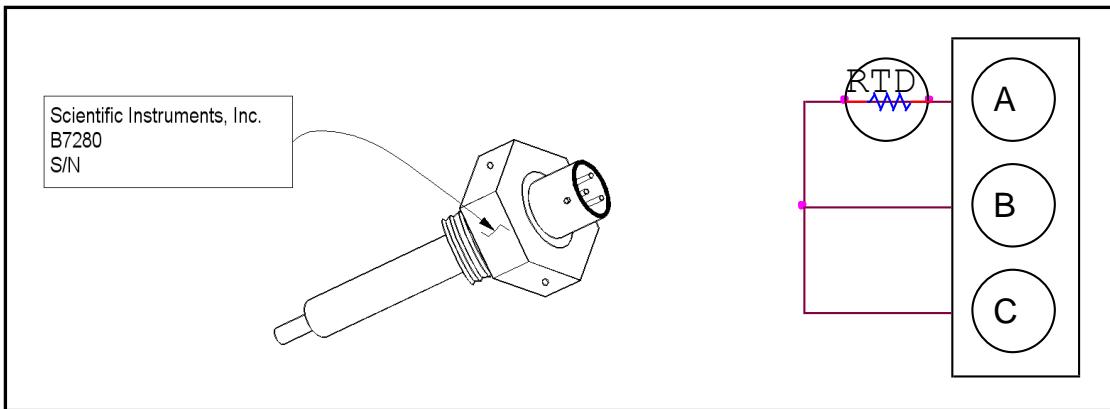

Outline and Schematic Drawing
Figure 1

TESTING AND FAULT ISOLATION

4. TESTING AND FAULT ISOLATION

A. The data that follows permits the testing of the sensor to insure correct operation.

B. Special Tools and Test Equipment

- (1) A megohmmeter capable of reading 10 megohms and greater at 50 VDC (AEMC Model 1000, or equivalent)
- (2) Temperature-controlled environmental test chamber. Accuracy 1%.
- (3) Thermometer with temperature accuracy $\pm 0.11^{\circ}\text{C}$ ($\pm 0.2^{\circ}\text{F}$)
- (4) Ohmmeter with:
 - Current: $< 0.1\text{ mA}$
 - Accuracy: 0.05%
 - Range: 0-100 K Σ

C. Visual Check

- (1) Visually check the sensor for obvious damage.

D. Insulation Resistance

- (1) Using the megohmmeter, measure the resistance between all receptacle pins and the housing. The reading should exceed 400 megohms @ 50 VDC.

E. Electrical Test (refer to Figure 2)

- (1) Connect the Ohmmeter to pins A & B of the temperature sensor. Hold the sensor at a temperature of $0^{\circ}\text{C} \pm 3^{\circ}\text{C}$ ($32^{\circ}\text{F} \pm 5.4^{\circ}\text{F}$), within the environmental test chamber. With the thermometer at a stable temperature and located within approximately 12.7 mm ($\frac{1}{2}$ ") of the tip of the sensor, measure the temperature. Compare this value to that indicated on Figure 3. The value must be within the limits shown on the drawing.
- (2) Increase the temperature of the environmental test chamber to $100^{\circ}\text{C} \pm 3^{\circ}\text{C}$ ($212^{\circ}\text{F} \pm 5.4^{\circ}\text{F}$). Measure the temperature. Note the value of the resistance from the ohmmeter. Compare this value to that indicated on Figure 4. The value must be within the limits shown on the drawing.

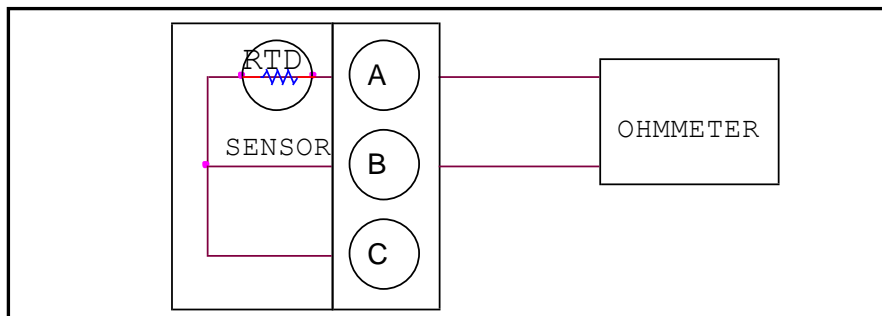

Schematic for Electrical Test
Figure 2



COMPONENT MAINTENANCE MANUAL
B7280

Resistance vs Temperature

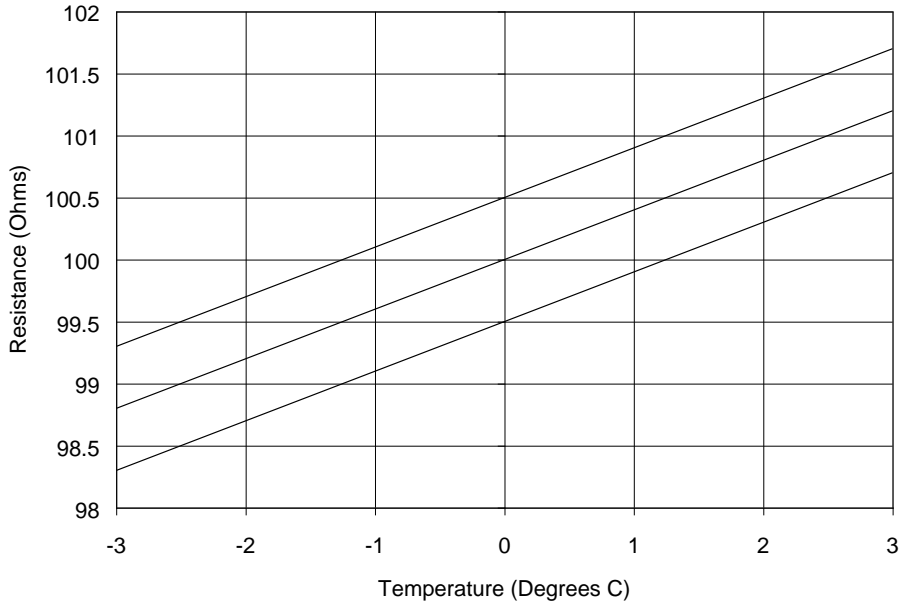

Resistance vs Temperature
Figure 3

Resistance vs Temperature

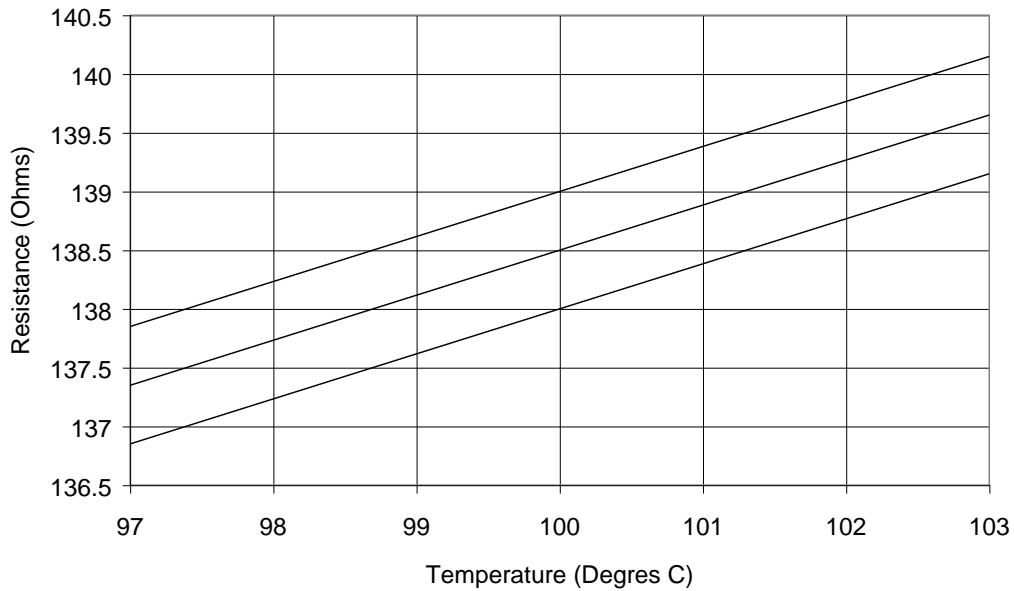

Resistance vs Temperature
Figure 4



COMPONENT MAINTENANCE MANUAL
B7280

5. DISASSEMBLY

- A. Not applicable

6. CLEANING

- A. Remove dirt, stains, moisture, etc. with a clean, dry, lint-free cloth.
- B. Use a soft bristle brush moistened in isopropyl alcohol to remove any foreign matter from between the receptacle pins.

7. CHECK

- A. Visually inspect the sensor probe for obvious wear or damage.
- B. Check for bent, broken or missing receptacle pins.
- C. Check probe housing for scratches or cracks.

8. REPAIR

The temperature sensor is considered non-repairable. Bent receptacle pins may be carefully straightened. For other defects or incorrect operation, the temperature sensor should be discarded.

9. ASSEMBLY INCLUDING STORAGE

A. Assembly

- (1) Not Applicable

B. Storage

- (1) Install a protective cap on the electrical connector.
- (2) Keep the sensor in a clean and dry room open to the air. The temperature must be between 18°C and 28°C (64°F and 82°F) and the relative humidity between 25% and 65%.



COMPONENT MAINTENANCE MANUAL
B7280

- (3) Keep the sensor in its initial packaging. If other containers are put on the sensor container, be careful to prevent damage caused by too much weight.
- (4) Do not keep the sensor near heat, fluids or other sources that can cause corrosion.

10. FITS AND CLEARANCES

No dimensional check of the sensor is necessary.

11. SPECIAL TOOLS, FIXTURES AND EQUIPMENT

No other special tools are necessary.

12. ILLUSTRATED PARTS LIST

Since the unit is non-repairable, no parts list is provided.