



COMPONENT MAINTENANCE MANUAL
B7320

DESCRIPTION AND OPERATION

1. DESCRIPTION

The Temperature Sensor, Model B7320, consists of two calibrated negative temperature coefficient (NTC) thermistors, which are located within the tip of a nylon probe assembly. The probe connector flange is drilled for mounting on an aircraft duct, as illustrated in Figure 1.

2. OPERATION

The resistance of the NTC thermistors varies in direct proportion to changes in the duct air temperature. The thermistors are terminated at pins A & B and D & E of a 6-pin, hermetically sealed, stainless steel receptacle, which is fastened to the probe body. This receptacle provides the interface between the thermistors and an associated temperature controller. The controller processes the thermistors signal to monitor and regulate the aircraft temperature control system.

3. SPECIFICATIONS

Receptacle: FDBA 50H-10-6PN-K
(or equivalent)

*Mating Connector: MS3476L106S
(or equivalent)

Weight: 0.025 kg (0.88 oz) maximum

Size:

Probe Tip: 11.99 mm (0.472 in.)

Overall Length: 46.99 mm (1.850 in.) maximum

* This plug is listed for test purposes only, and is not necessarily used on the aircraft.

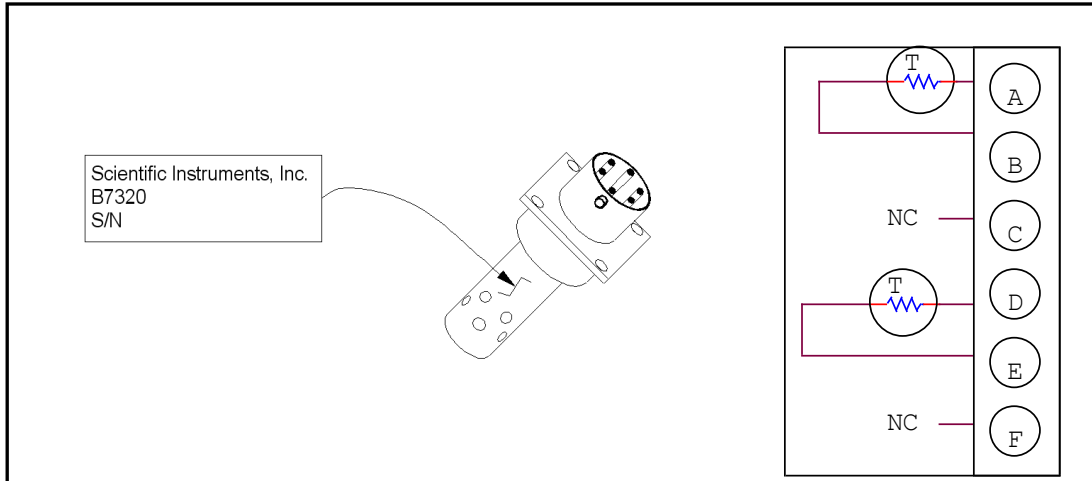

Outline and Schematic Drawing
Figure 1

TESTING AND FAULT ISOLATION

4. TESTING AND FAULT ISOLATION

A. The data that follows permits the testing of the sensor to insure correct operation.

B. Special Tools and Test Equipment

- 1) A megohmmeter capable of reading 400 megohms and greater at 50 VDC (AEMC Model 1000, or equivalent)
- 2) Temperature-controlled environmental test chamber. Accuracy 1%.
- 3) Thermometer with temperature accuracy $\pm 0.2^{\circ}\text{F}$ ($\pm 0.11^{\circ}\text{C}$)
- 4) Ohmmeter with:

Current: $<0.1 \text{ mA}$

Accuracy: 0.05%

Range: 0-100 $\text{K}\Omega$

C. Visual Check



COMPONENT MAINTENANCE MANUAL
B7320

- 1) Visually check the sensor for obvious damage.

D. Insulation Resistance

- 1) Using the megohmmeter, measure the resistance between all receptacle pins and the connector housing. The reading should exceed 400 megohms @ 50 VDC.

E. Electrical Test (refer to Figure 2)

- 1) Connect the Ohmmeter to pins A & B of the temperature sensor. Hold the sensor at a temperature of $18^{\circ}\text{C} \pm 1^{\circ}\text{C}$ ($64.4^{\circ}\text{F} \pm 1.8^{\circ}\text{F}$), within the environmental test chamber. With the thermometer at a stable temperature and located within approximately 12.7 mm (1/2 in.) of the tip of the sensor, measure the temperature. Compare this value to that indicated on Figure 3. The value must be within the limits shown on the drawing.
- 2) Connect the Ohmmeter to pins D & E of the temperature sensor. Hold the sensor at a temperature of $18^{\circ}\text{C} \pm 1^{\circ}\text{C}$ ($64.4^{\circ}\text{F} \pm 1.8^{\circ}\text{F}$), within the environmental test chamber. With the thermometer at a stable temperature and located within approximately 12.7 mm (1/2 in.) of the tip of the sensor, measure the temperature. Compare this value to that indicated on Figure 3. The value must be within the limits shown on the drawing.
- 3) Connect the Ohmmeter to pins A & B of the temperature sensor. Hold the sensor at a temperature of $30^{\circ}\text{C} \pm 1^{\circ}\text{C}$ ($86^{\circ}\text{F} \pm 1.8^{\circ}\text{F}$), within the environmental test chamber. With the thermometer at a stable temperature and located within approximately 12.7 mm (1/2 in.) of the tip of the sensor, measure the temperature. Compare this value to that indicated on Figure 4. The value must be within the limits shown on the drawing.
- 4) Connect the Ohmmeter to pins D & E of the temperature sensor. Hold the sensor at a temperature of $30^{\circ}\text{C} \pm 1^{\circ}\text{C}$ ($86^{\circ}\text{F} \pm 1.8^{\circ}\text{F}$), within the environmental test chamber. With the thermometer at a stable temperature and located within approximately 12.7 mm (1/2 in.) of the tip of the sensor, measure the temperature. Compare this value to that

COMPONENT MAINTENANCE MANUAL B7320

indicated on Figure 4. The value must be within the limits shown on the drawing.

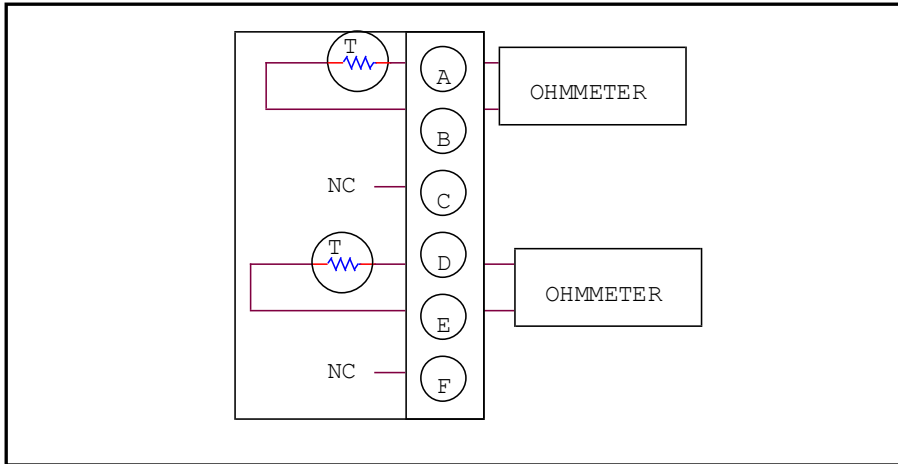

Schematic for Electrical Test
Figure 2

Resistance vs Temperature

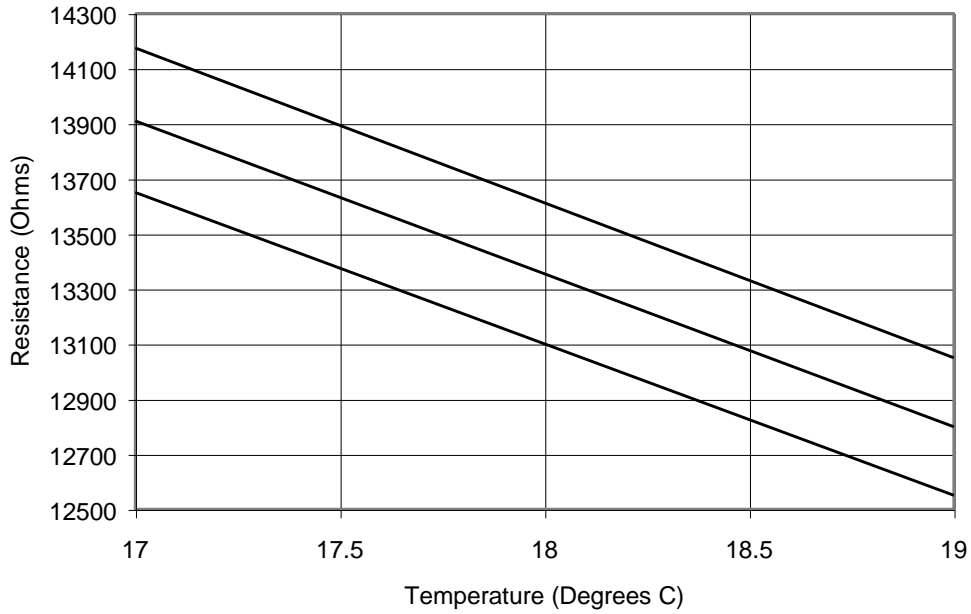

Resistance vs Temperature
Figure 3



COMPONENT MAINTENANCE MANUAL
B7320

Resistance vs Temperature

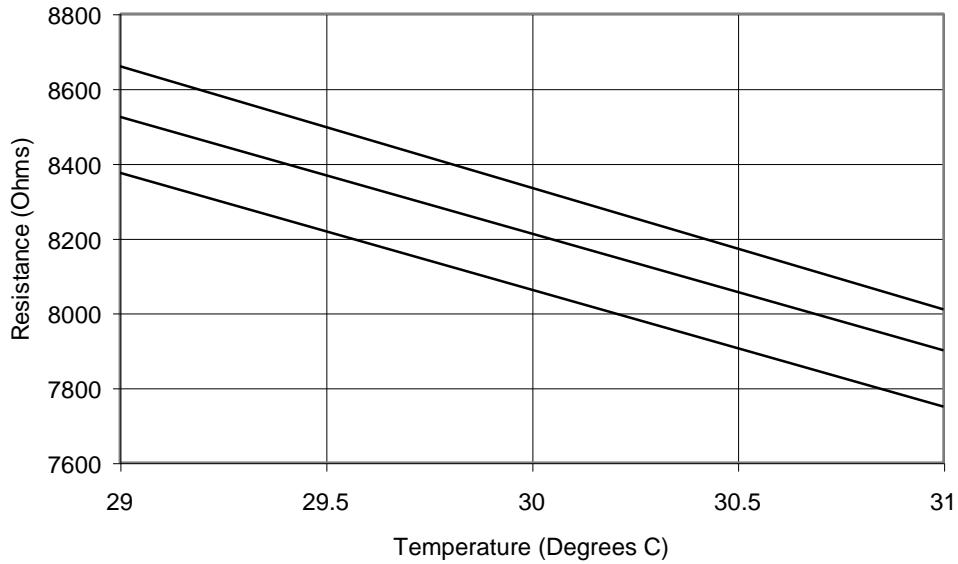

Resistance vs Temperature
Figure 4

5. DISASSEMBLY

Not Applicable

6. CLEANING

- A. Remove dirt, stains, moisture, etc. with a clean, dry, lint-free cloth.
- B. Use a soft bristle brush moistened in isopropyl alcohol to remove any foreign matter from between the receptacle pins.

7. CHECK

- A. Visually inspect the sensor probe for obvious wear or damage.
- B. Check for bent, broken or missing receptacle pins.
- C. Check probe housing for scratches or cracks.



COMPONENT MAINTENANCE MANUAL
B7320

8. REPAIR

The temperature sensor is considered non-repairable. Bent receptacle pins may be carefully straightened. For other defects or incorrect operation, the temperature sensor should be discarded.

9. ASSEMBLY INCLUDING STORAGE

A. Assembly

Not Applicable

B. Storage

- 1) Install a protective cap on the electrical connector.
- 2) The sensor must be stored in a clean and dry room open to the air. The temperature must be between 18°C and 28°C (64°F and 82°F) and the relative humidity between 25% and 65%.
- 3) Keep the sensor in its initial packaging. If other containers are put on the sensor container, be careful to prevent damage caused by too much weight.
- 4) Do not keep the sensor near heat, fluids or other sources that can cause corrosion.

10. FITS AND CLEARANCES

No dimensional check of the sensor is necessary.

11. SPECIAL TOOLS, FIXTURES AND EQUIPMENT

No other special tools are necessary.

12. ILLUSTRATED PARTS LIST

Since the unit is non-repairable, no parts list is provided.